

(CBCGS DEC 2017)
PRODUCTION PROCESS 1

Q1) Solve any four:

A) What are transfer machines?

[5]

Solution:

The term transfer indicates the transfer of work piece from one station to another station during the manufacturing process. The unmachined work pieces are loaded at one end and the machined work piece leave the transfer line at the other end. The transfer machine or transfer line consists of several machining heads, or units fastened together by conveying units. Transfer machines permit the maximum number of operations to be performed on work pieces at a maximum production rate.

Transfer units are commonly used in automobile industry, air-craft industry, etc.

Transfer machines can be of the following types:

- In-line transfer machine.
- Rotary Indexing table transfer machine.
- Drum Type transfer machine.

Q1) B) Explain rolling defects

[5]

Solution:

The defects that are commonly observed in rolled products include the following:

- Folds: Folds occur during plate rolling when reduction per pass is very small.
- Lamination: Small crack appears when reduction in thickness is quite high.
- Edge cracking: This defect is caused either due to low ductility of the work material or because of uneven deformation near the ends. Cracks are caused during cold rolling if the metal becomes too much work hardened.
- Fins: Fins are formed on the rolled bars when the metal forces itself in the space between the rolls. Fins can lead to folds, cracks etc.
- Alligatoring: Alligatoring is splitting of the work piece along a horizontal plane on the exit side. This defect occurs during slab rolling of aluminum alloys.

OUR CENTERS :

KALYAN | DOMBIVLI | THANE | NERUL | DADAR

Contact - 9136008228

Q1) C) How is rod made by extrusion.

[5]

Solution:

Extrusion is a process used to create objects of a fixed cross-sectional profile. A material is pushed through a die of the desired cross-section. The two main advantages of this process over other manufacturing processes are its ability to create very complex cross-sections, and to work materials that are brittle, because the material only encounters compressive and shear stresses. It also forms parts with an excellent surface finish.

A rod is made by Forward Hot Extrusion process:

In this process the metal billet is heated to forging temperature and placed in a heavy built cylinder chamber made up of steel. A ram or plunger then advances behind the billet and forces the metal through an opening at the other end. A steel disc having a diameter slightly less than the diameter of the steel chamber and the thickness, 50 to 75 percent of its diameter is kept between the hot billet and the ram. This disc is called dummy block and protects the ram from the heat. The ratio of the cross section area of billet to that of the extruded section is called the extrusion ratio. It usually ranges from 20 to 50. Lower side values are used when a billet is first extruded to an intermediate diameter and then reduced to final size in the next step.

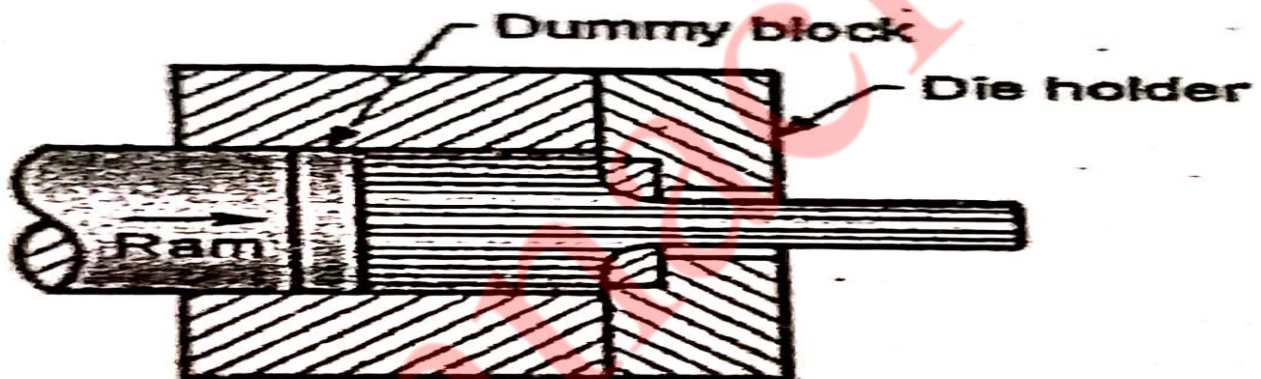

Q1) D) With neat sketch explain the working principle of plastic injection moulding process. [5]

Solution:

An injection molding machine consists of three main parts: the injection unit, the mold - the heart of the whole process - and the clamping/ejector unit.

Operation:

The main working principle of plastic molding machine is to use the plastic thermal physical properties. First, we auto loader the plastic material into the barrel, which is surround by heating elements melting the plastic. In the barrel which is assembled with servo motor screw. The plastic melt will flow up the screw and under the heating condition get tight and move forward to the screw head. At the same time, due to the plastic reacting force, the screw will step back. So at the screw head, it formed a plastic melt saving space to finish its plasticizing process. At the same time, under the injection hydraulic cylinder force, the screws will injection the plasticizing melt into the plastic mould through the nozzle. The plastic melt will remain in the mould cavity through the holding pressure, cooling, process, and then formed into solid shape ejected out of the mould. So the plastic molding machine main recycle process including: quantitative feeding-plasticizing-injection-molding the shape-pick up the piece, then close the mould to the 2nd recycle process.

OUR CENTERS :

KALYAN | DOMBIVLI | THANE | NERUL | DADAR

Contact - 9136008228

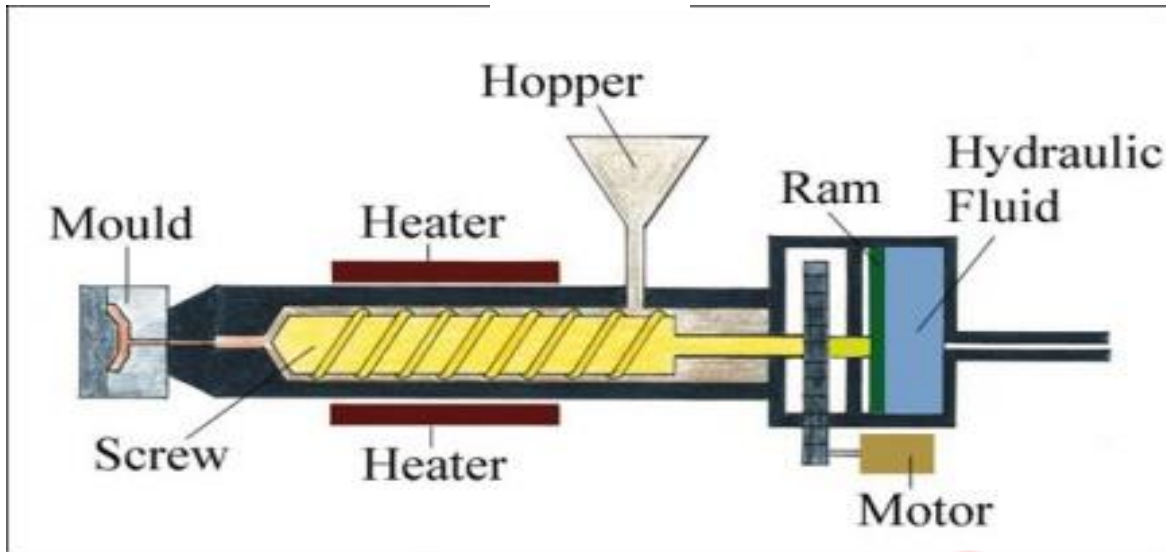

Two arrangements of injection moulding are in use:

- Plunger or ram type injection moulding
- Screw type injection moulding

Q1) E) Differentiate between shaper and planar.

[5]

Solution:

Sr.No.	Shaper	Planer
1.	Shaper is used to machine small work piece which can fit on the table.	It can work with large size of work piece.
2.	Tool is the moving part in shaper machine.	Work piece is the moving part in planer.
3.	Work piece remain stationary on this machine.	Tool remains stationary on planer.
4.	It is light duty machine.	It is a heavy duty machine.
5.	It can use only one cutting tool at a time.	It is equipped more than one cutting tool at a time.
6.	It uses single point cutting tool.	It also used single point cutting tool but more than one tool can be used at same time.
7.	Shaper is used quick return mechanism to drive the ram. In modern machine hydraulic drive is also used.	Planer is driven by gear or hydraulic arrangement.
8.	It gives poor accuracy compare to planer.	It gives higher accuracy.
9.	Shaper is smaller in size and gives slow cutting speed. It is not suitable where productivity is prime concern.	It is larger in size and gives large productivity.
10.	The stroke length can be adjustable.	Stroke length can be adjusted.

OUR CENTERS :

KALYAN | DOMBIVLI | THANE | NERUL | DADAR

Contact - 9136008228

Q2) A) Differentiate the following:

(i) Pattern and core boxes.

[5]

Solution:

Sr. No.	Parameters	Pattern	Core boxes
1	Used for	Making the mould.	Make the core.
2	Purpose	To create cavity for molten material.	To make cores.
3	Types	Loose, gated, match plate, Cope and drag, Shell, built-up, lagged.	Half, Dump, Split, Strickle, Left and Right hand, Gang.
4	Materials	Wood, Metals, Plastic, Plaster.	Wood.
5	Supports	Core prints.	Not needed.

Q2) A) (ii) Lapping and honing.

[5]

Solution:

Sr. No.	Characteristics	Lapping	Honing
1	Purpose	<ol style="list-style-type: none"> To obtain good dimensional and geometrical accuracy. To obtain good surface finish. To ensure close fit between mating parts. Correction of minor imperfection on the surface. 	Mostly used for finishing of surface of bores but can also be used for external cylindrical surfaces and flat surface.
2	Form in which abrasive is used	<ol style="list-style-type: none"> Loaded on a lap. Carried in a suitable vehicle. Bonded abrasive wheel. 	Bonded in the form of stones.
3	Machines used	Vertical lapping machines, Centreless lapping machines, Lapping machines.	Horizontal honing machines, Vertical honing machines.
4	Dimensional accuracy achievable	5 microns	2 to 3 microns
5	Surface finish	0.1 to 0.4 microns	0.2 to 0.3 microns

OUR CENTERS :

KALYAN | DOMBIVLI | THANE | NERUL | DADAR

Contact - 9136008228

Q2) B) Differentiate between TIG and MIG

[5]

Solution:

Sr. No.	TIG	MIG
1	No consumable electrodes are used.	Consumable electrodes are used.
2	Electrodes are used of tungsten or tungsten alloys.	Bare welding wire is made of desired composition.
3	Electrode only generates an arc and does not melt.	Electrode generates an arc and melts also.
4	Easier for thin plates and small parts.	Widely used for thick plates (above 4mm).
5	Welding torch is water cooled.	Welding torch is air or water cooled.
6	Used for joining dissimilar metals.	Used for joining similar metals.
7	It is a slow process.	It is a faster process.
8	During the process, separate filler material is used.	In this process, metal electrode will act as a filler material.
9	Cost of equipment is lower than MIG.	Cost of equipment is high.

OUR CENTERS :

KALYAN | DOMBIVLI | THANE | NERUL | DADAR

Contact - 9136008228

Q2) C) Differentiate between soldering and brazing.

[5]

Solution:

Sr.no.	Soldering	Brazing
1	The filler metal flows between the joints by capillary action.	Filler metal is fed at one end or more points in the assembly and drawn onto the rest of the joint by capillary action.
2	Filler metal has melting point below 450°C.	Filler metal has melting point above 450°C.
3	The joint is weak.	Joint is strong.
4	The joint is weak resistant to corrosion.	Better corrosion resistance.
5	Used for carbon, low alloy steels, cast irons, Al alloys.	Used for Cu, steels, Al, Mg and alloys.
6	Fillers are alloys of lead and tin in various properties.	Filler used in brazing include Cu and Cl alloys, Silver alloys and Al alloys.
7	Heat is applied with a soldering iron.	Heating is done by torch, furnace, induction, resistance, infrared techniques.
8	Fluxes use includes zinc chloride, ammonium chloride.	Fluxes used include borax and boric acid.

Q3) A) Explain rotary swaging with its sketch.

[6]

Solution:

The term swaging is applied loosely to a variety of operations in which the forming takes place due to squeezing action and the material is free to flow perpendicular to the direction of applied force. The most common used is rotary swaging which is used to reduce diameter, generally over one part of the length of a rod, bar, or tube. It may also be used to reduce the diameter of tapered work piece. Rotary operation is done in a rotary swaging machine or rotary swagger. The dies are engaged in a slot provided on the machine spindle which rotates at a fairly high speed. The race surrounding the spindle rotates the dies between pairs of opposite rolls. As the spindle rotates, the dies pass between pairs of opposite rolls. As a result, the dies are closed and opened alternatively as the pass between the rollers and the gaps. The work piece is fed into the die jaws manually or mechanically. It is gradually squeezed to the desired size. The process is used for producing ratchets, sockets, various types of pins, pen caps, shaft, spacers, etc.

OUR CENTERS :

KALYAN | DOMBIVLI | THANE | NERUL | DADAR

Contact - 9136008228

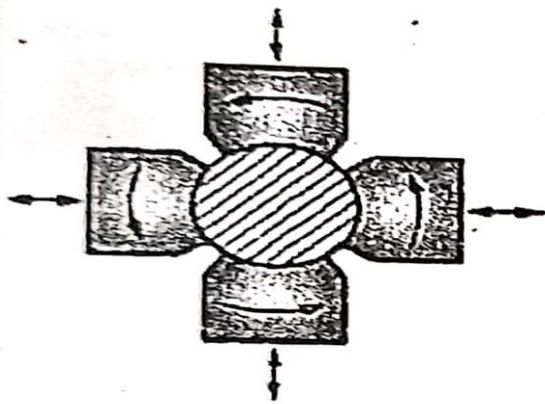

(a) Principle of rotary swaging

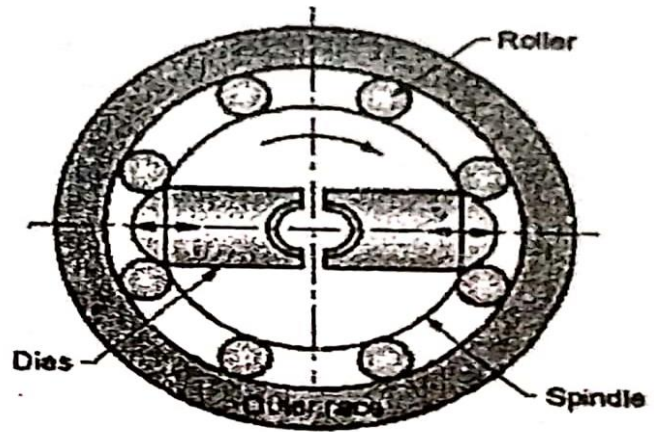

(b) Rotary swaging machine operation

Q3) B) Describe calendaring process for plastic with a neat labeled sketch.

[6]

Solution:

The term sheet refers to stock with thickness between 0.5mm to 6 mm. Film is below 0.5 mm. Calendaring is the process of making sheets and films of plastic.

In this method a mixture of resin, filler, plasticizer and color pigment is passed between a series of heated rollers. The process is similar to rolling process in that the material is compressed between the rolls and emerges as a sheet. The main difference between rolling and calendaring is that the pre-calendared material is not in the sheet form and in calendaring after the material has reached minimum thickness there is appreciable thickening of the material.

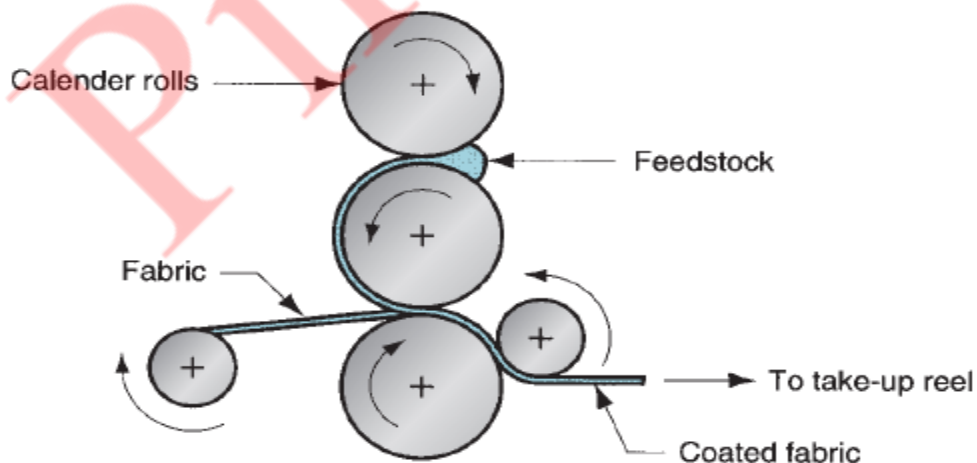

The first roll gap serves as a feeder, the second as a metering device and the third one sets the final gauge of the sheet which is wound on a coiler after cooling.

The roller squeezes the mixture into the shape of the sheet or film. The thickness is controlled by the speed of the rollers and the gap between the rollers. The finished product is cooled by passing it between a set of water cooled rolls.

E.g.: vinyl tiles and cellulose acetate sheets. Used for the production of rain wear, shower curtains, lamination sheets, etc.

Q3) C) How are milling machines classified with a neat sketch?

[8]

Solution:

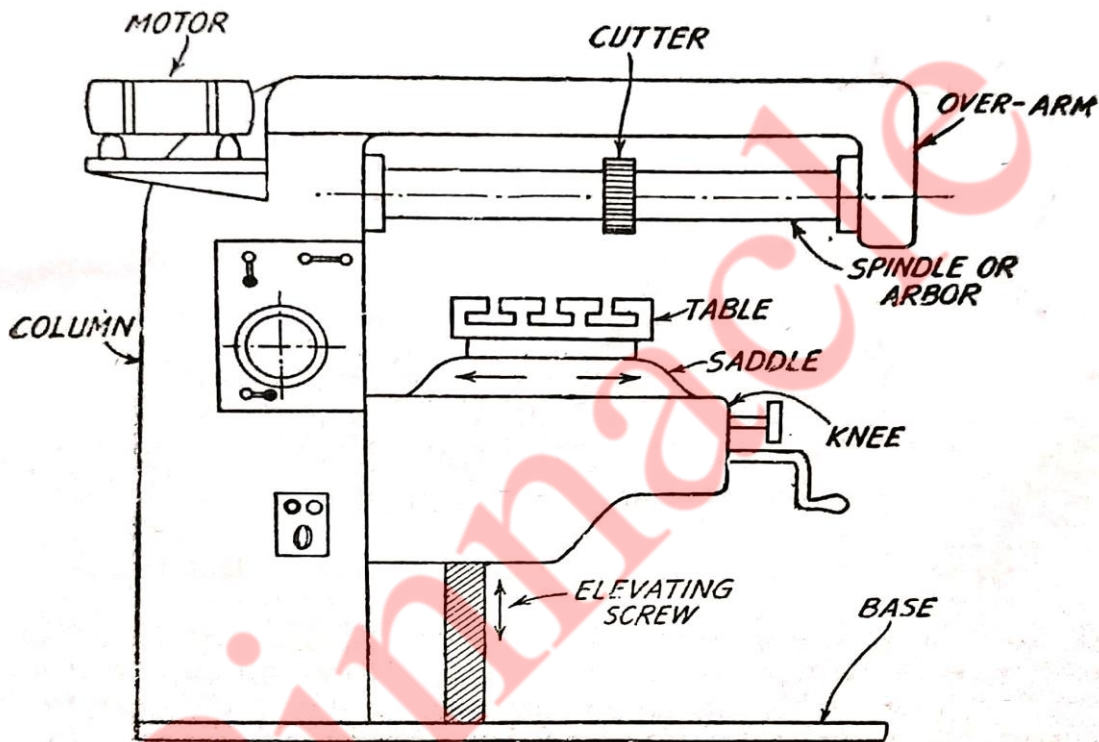

Milling machine

There are many types of milling machines, from simple hand mills to complex tape controlled machine.

The usual classification is in accordance with the general design but in every classification there is some overlapping. According to the design the distinctive classification is as follows:

- Column and knee milling machine
 - (a) Horizontal milling machine
 - (b) Vertical milling machine
 - (c) Universal milling machine
 - (d) Ram-type universal milling machine
- Bed type milling machine
 - (a) Simplex milling machine
 - (b) Duplex milling machine
 - (c) Triplex milling machine
- Plano-type milling machine
- Special purpose milling machine

OUR CENTERS :

KALYAN | DOMBIVLI | THANE | NERUL | DADAR

Contact - 9136008228

- (a) Rotary drum table milling machine
- (b) Drum milling machine
- (c) Profile milling machine
- (d) Duplicating milling machine
- (e) Planetary milling machine

Q4) A) Explain centreless grinding operation.

[5]

Solution:

A centreless grinding machine as the name suggest has no centres, drivers and other fixtures required for holding the work piece. It is used for grinding external cylinder surfaces, tapers and forms with rotational symmetry.

The essential units of the machines are the grinding wheel, the regulating wheel, the work rest blade and the slides. The regulating wheel and the work rest blade support the work piece. The regulating wheel also controls the speed and feed of the work piece. It is made of rubber bonded abrasive material with enough friction to provide a good grip on the surface speed of the regulating wheel.

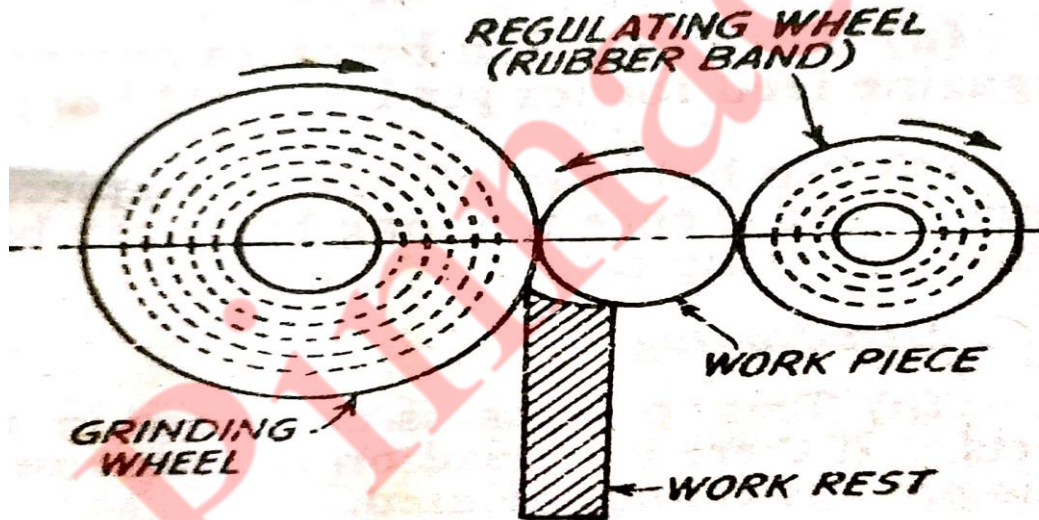

The surface speed of the regulating wheel is of the order 0.25 to 1 m/s. The regulating wheels are mounted on a slide so that its axis of rotation can be moved towards or away from work rest blade. This adjustment is required to accommodate jobs of different diameters on the machine for grinding. The work rest blade and the regulating wheel slide are mounted on yet another slide which is moved towards the grinding wheel for depth motion or in feed. The work piece is supported on a blade on the work rest. The surface of the blade is inclined towards the regulating wheel.

This operation of centreless grinding can be classified into three types:

- Through feed centreless grinding
- Infeed centreless grinding
- End feed centreless grinding

OUR CENTERS :

KALYAN | DOMBIVLI | THANE | NERUL | DADAR

Contact - 9136008228

Q4) B) Differentiate between core and core print.

[5]

Solution:

Sr. No.	Parameter	Core	Core print
1	Definition	Core is a solid mass in the mould that prevents the metal from filling some part of the mould.	Core print is the seat provided in the mould for supporting the core. The projection provided on the pattern for creating the core seat is also called core print.
2	Composition	Core is made from core sand or metal.	When provided on the pattern it is of the same material as the pattern.
3	Shape	The shape of the core corresponds to the shape of cavity to be created in the casting.	The shape of the core print is decided by the requirement of the core to be supported that is its type, weight, position, etc.
4	Core removal	Sand core are crushed and removed after the casting solidifies. Metal cores are removed just before solidification.	Core prints on the pattern leave the mould when pattern is withdrawn.
5	Characteristics	Core may be supported with chaplets.	Core prints may be given suitable taper to facilitate placement of core prints.

Q4) C) What is meant by a riser? State the functions of riser.

[5]

Solution:

The basic function of a riser is to provide feed metal to the solidifying casting. In addition, it acts as a large vent for evacuating the mould and takes care of the hydraulic ram effect. The riser should have sufficient quantity of hot material and should solidify after the casting it is to feed. The gating system should be such as to provide a suitable temperature gradient towards the riser.

The area at the junction of the riser to the casting should be large enough so that the riser is not choked. For the riser to feed the casting its cooling rate has to be lower than that of the casting. This is attained by keeping the volume to area ratio of the riser larger than the volume to area ratio of casting. The riser should be located as far as possible, near the top of the mould to take advantage of the gravity head of the metal.

OUR CENTERS :

KALYAN | DOMBIVLI | THANE | NERUL | DADAR

Contact - 9136008228

The shape of the riser is an important parameter in this design. The metal feed volume requirements being very small mostly riser sizes are guided by cooling rate considerations. The most economical riser is the one which gives the desired low cooling rate with minimum amount of metal.

Risers may be open or blind. An open riser has its upper surface open to atmosphere. Blind risers are rounded cavities completely surrounded by moulding sand. Such risers do not extend to the top of the mould and means have to be provided to make the atmospheric pressure reach the molten metal in these risers.

Q4) D) Discuss friction welding with its applications.

[5]

Solution:

Friction welding is a solid state welding process in which the heat required for welding is obtained by friction between the ends of the parts to be joined.

The sequence of operations for the process is as shown in diagram.

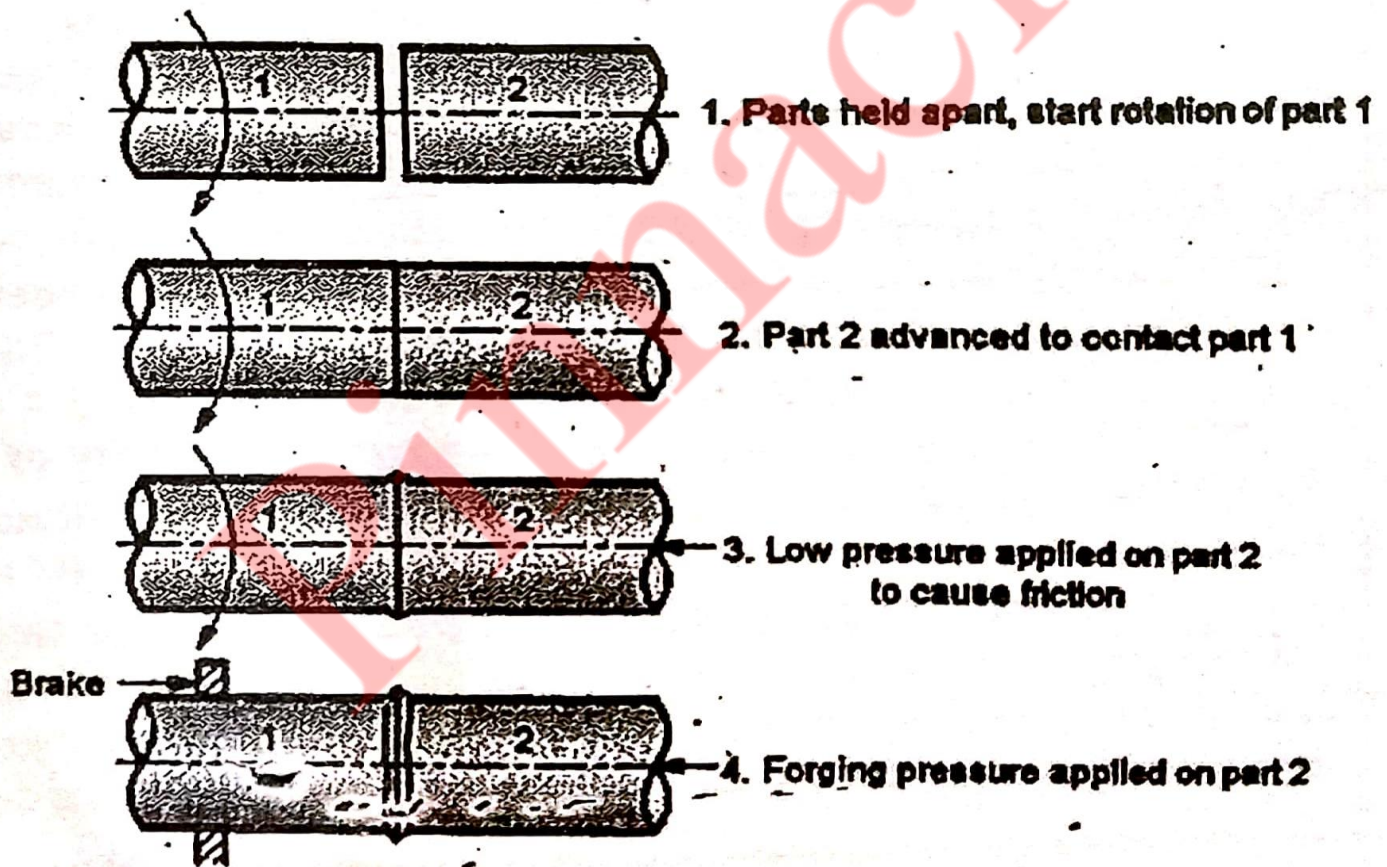

-One of the parts to be welded is rotated at about 3000 RPM with the other part axially aligned with it.

- The second part is advanced to the rotating part and made to rub against it.

- Slight axial pressure is applied on the second part to cause friction between two parts. The temperature at the interface increases and the metal at the interface become soft to permit formation of forged joint.

OUR CENTERS :

KALYAN | DOMBIVLI | THANE | NERUL | DADAR

Contact - 9136008228

- After sufficient heating has taken place, the power drive is disconnected and the parts are abruptly broken. The axial pressure is increased to forge the two parts together.

Friction welding is carried out on specially designed machines similar to centre lathe but not much more rigid and having higher power rating and quick disengagement features. The power required for friction welding varies between 25 kVA to 175kVA and the axial pressure may range from 40MPa for low carbon steel to about 450 MPa for alloy steels.

Friction welding process has the following main advantages:

- The process is simple and mostly automatic. Even semi-skilled operator can be employed.
- Cleaning of the components is not critical. Any oxides or contaminants present get removed during initial rubbing.
- The temperature involved is lower than those in fusion welding.
- There is not much distortion or warping.
- Even dissimilar metals can be joined as there is no melting involved.
- The quality of weld is very good.
- Due to these features, friction welding is used extensively in aviation and automobile industry.

Q5) A) State various vertical machining centres. Describe any one in detail.

[8]

Solution:

A machining centre is a computer controlled machine tool capable of performing a variety of cutting operations on different surfaces of a work piece without having to move the work piece from one machine to another.

Machining centres are classified as:

- Horizontal machining centre
- Vertical machining centre

Vertical Machining Centre:

It carries a vertical machining head which can slide along the vertical guide-ways provided on the column. The vertical head can be tilted in either direction. These machines are also very heavy in construction. These machines are suitable for machining flat surfaces with deep cavities like the manufacturing of mould, dies, etc.

OUR CENTERS :

KALYAN | DOMBIVLI | THANE | NERUL | DADAR

Contact - 9136008228

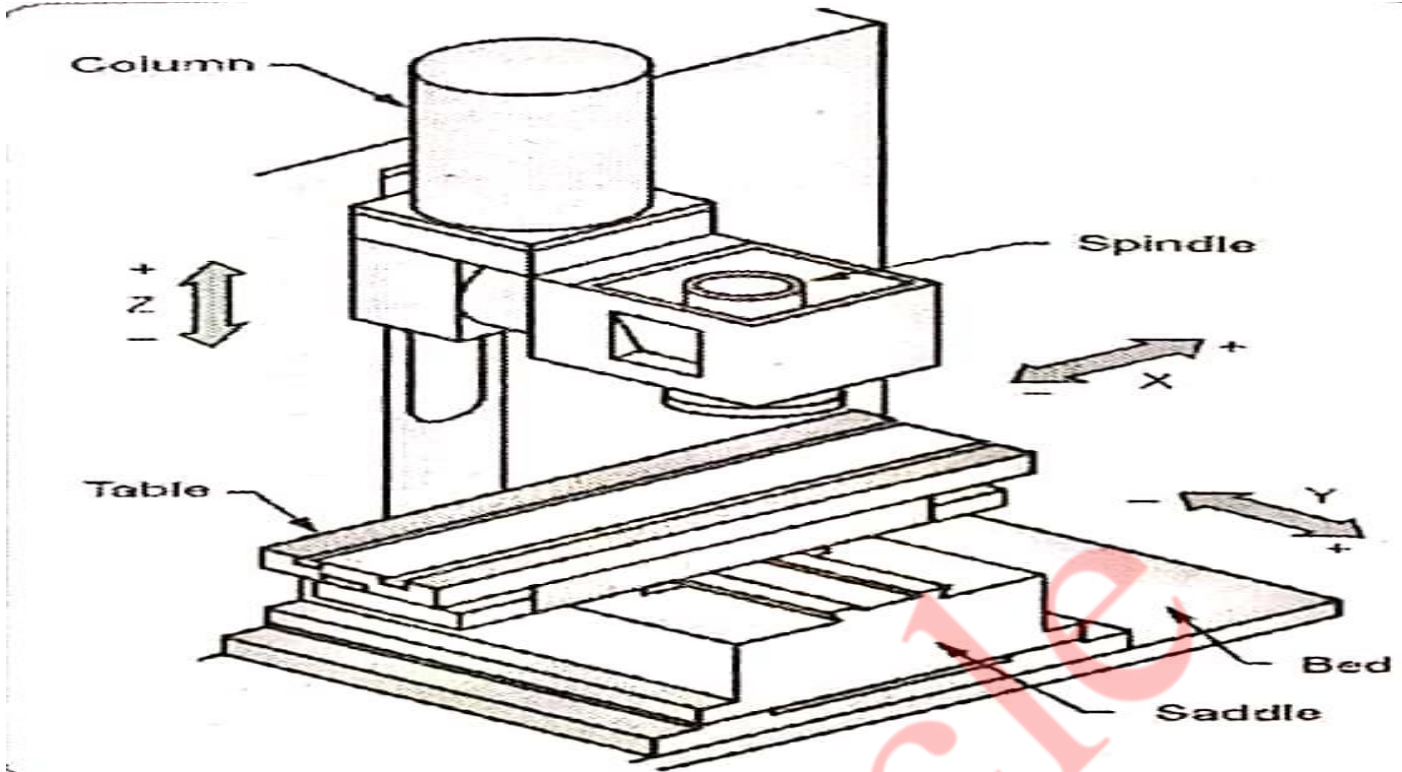

The vertical machining centre machines have following parts:

- Bed: It is a heavy structure which supports the complete machine and carries guide-ways over its top surface.
- Saddle: It is mounted over the guide-ways on the bed and also carries column over it. It provides Y axis movement to the machines.
- Table: It is mounted over the guide-ways provided on the saddle. It provides X axis movement to the machines.
- Column: It is mounted over saddle. It provides Z axis movement to the machine.
- Automatic Tool Changer: It is used to change the tool from the machine spindle rapidly.
- Spindle and servo system: Spindle is mounted on the back stock and it provides Z axis movement to the machining centre. Servo system contain of servo motors and feedback system. It provides accurate and rapid movement to all the axis.

OUR CENTERS :

KALYAN | DOMBIVLI | THANE | NERUL | DADAR

Contact - 9136008228

Q5) B) Differentiate between open loop and closed system in CNC machines.

[6]

Solution:

Sr.No.	Characteristics	Open loop system	Closed loop system
1	System	This is cheaper and simple system.	This comparatively costlier and more complicated system.
2	Feedback arrangement	Does not have a feedback mechanism.	It has feedback system.
3	Machine system	The machine tool controls have only motion control but do not have any provision for a feedback which needs to be compared with the input for better controls.	The machine tool controls have a motion control with provision for feedback which can be used for accurately controlling the drive system.
4	Accuracy of nob	Because of the absence of feedback there is no built in check on the motion imparted.	Feedback system provides a comparison between the motion imparted and motion intended. Hence better accuracy.

Q5) C) Explain vacuum forming process of polymer.

[6]

Solution:

In this process the mould is made from reclaimable dry sand and is vacuum sealed in a plastic film. Due to application of vacuum the surface finish is excellent, and vacuum holds the mould rigid during the pouring the solidification of casting.

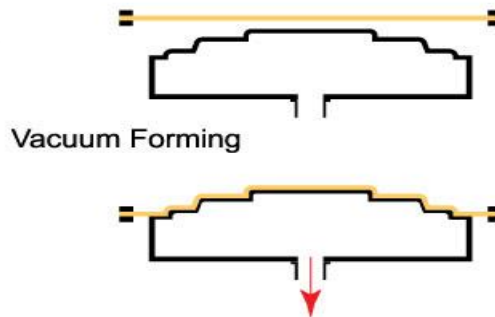

A vacuum chamber is fitted beneath a pattern plate. Thus when a pattern is mounted over the pattern plate, the vacuum chamber can be connected to the pattern. After placing the pattern, a heated plastic film is placed over the pattern and drawn down on to it by vacuum. A moulding box is placed over the pattern and vibrated. After forming the feeder and risers, the top of the mould is sealed with a second plastic sheet

OUR CENTERS :

KALYAN | DOMBIVLI | THANE | NERUL | DADAR

Contact - 9136008228

and a vacuum is applied to the box to compact the dry sand. The mould is then ready for pouring after withdrawing pattern plate. The other half of the mould is produced in similar manner. Two halves are assembled and filled with molten metal. During pouring, a vacuum is applied to both upper and lower boxes.

Q6) A) What is meant by forging? Differentiate closed and open die forging.

[5]

Solution:

Forging:

Forging is the process of forming metal by the application of intermittent blows or pressure to individual work pieces. It is a process of plastically deforming metals or alloys to a specific shape by applying compressive forces. Unlike rolling the products of the forging process is not a continuous flowing mass but discrete piece. Unless specifically stated otherwise forging is understood as a hot working process but cold forging is also sometimes used.

Difference between closed and open die forging:

Sr. No.	Parameter	Closed die forging	Open die forging
1	Process	Metal is confined in a die cavity of the shape desired and compressed.	Shaping is done by compressing the work piece between two flat die.
2	Metal Deformation	During compression the metal flows and fills the die cavity completely.	The shape is given by specified blows on different faces of the work piece.
3	Use	Closed impression dies are used in drop forging and die forging operations	This includes most shaping operations.
4	Accuracy	The accuracy of the shape produced depends on the designing die cavity.	The accuracy of the shape produced depends on the skill of the operator.
5	Complexity of products	Comparatively more complex shapes can be produced particularly when using multiple impression dies.	The shapes produced are simple like style, discs, rings, etc.
6	Die cost	Higher	Lower.
7	Post forging operation	No final machining is necessary.	The product may need to be finished by machining.

OUR CENTERS :

KALYAN | DOMBIVLI | THANE | NERUL | DADAR

Contact - 9136008228

Q6) B) Write short note on following:

[10]

(i) Machine tools classification

[5]

Solution:

Machine tools are defined as a tool which while holding the cutting tool would be able to remove metal from the work piece. Material is removed from the work piece in order to generate desired shape. Some examples of M/C tools are milling cutter, drill bit, shaper etc.

(a) On the basis of production capability M/C tools can be classified into following four types

1. General purpose machine tools: They can be used for almost any type of application but, the speed of production is very low.
2. Production machine tools: Slightly more productive than general purpose M/C tools and are used for production purposes.
3. Special purpose machine tools: They are specially made for mass production and are designed for particular application.
4. Single purpose machine tools: They are used for highly automated production processes, where the production rate is very high. They are least flexible.

(b) Classification based on cutting points in M/C tool

1. Single point cutting tools: They have only one cutting edge for example, tool used in turning in lathe.
2. Multi points cutting tools: They have more than one cutting edge for example milling cutter, drill, hacksaw etc.

Q6) B) (ii) Automatic machines

[5]

Solution:

Automatic machines are those machines in which both the work piece handling and the metal cutting operations are performed automatically. These machines have played important role in increasing the production rate and have been in use for long time. Initial process is done very carefully; the process is repeated automatically to produce duplicate parts without participation of operator. In automatic machines, right from feeding of stock to clamping, machining and even inspection of the work piece is carried out automatically. A particular sequence is followed depending upon the requirements of the work piece and is achieved by using cams, stops, settings, trip dogs and other mechanical movements of the machines.

During the recent years the concept of automatics has changed altogether due to introduction of automatic feedback control circuits and the electronic computers. Under the principle of feedback system the information from the elements being controlled, i.e. the tool or cutter is fed back electrically into the controlling system where it is compared from set value and the tool is then accordingly moved and thus a continuous system of monitoring and corrections is used.

OUR CENTERS :

KALYAN | DOMBIVLI | THANE | NERUL | DADAR

Contact - 9136008228

Q6) C) Compare transfer moulding and compression moulding.

[5]

Solution:

Sr. No.	Parameter	Transfer moulding	Compression moulding
1	Process difference	Material is heated in a separate chamber and then forced into mould cavity.	Material is heated in the mould itself.
2	Production rate	High	Low
3	Curing time	Less	More
4	Quality of work	Good	Good
5	Components produced	More complex than compression moulding, particularly suitable for parts with metal inserts and slender cores.	Less complex parts
6	Applications	Manufacture of electronic components, integrated circuits studs, pins, connectors.	Flatware, dishes, gears, handles, knobs, buttons.

OUR CENTERS :

KALYAN | DOMBIVLI | THANE | NERUL | DADAR

Contact - 9136008228